



# **TURBO HP**









## *TURBO-JET modular*





**ENGLISH**

### **INDEX**







	<b>Page</b>
— GENERAL 50 HZ RUNNING DATA.....	14
— GENERAL 60 HZ RUNNING DATA.....	15
— INTRODUCTION.....	16
— SIGNALS AND WARNINGS .....	16
— INSTALLATION AND STARTING .....	17
— ROUTINE MAINTENANCE.....	21
— EXTRAORDINARY MAINTENANCE.....	22
— IMPORTANT NOTICES.....	23
— TRANSPORT AND STORAGE.....	23
— TRANSPORT OF SECOND-HAND APPLIANCES .....	23
— PICTURES .....	61

## General 50 Hz running data Dental aspirator

Model	TURBO-JET 1 modular	Turbo HP due	Turbo HP tre	Turbo HP tre	Turbo HP tre 2V	Turbo HP tre 2V	Turbo HP quattro	Turbo HP quattro	Turbo HP quattro 2V
		TURBO-JET 2 modular							
Rated voltage	230 V ~	230 V ~	230 V ~	400 V 3 ~	230 V ~	400 V 3 ~	230 V ~	400 V 3 ~	400 V 3 ~
Rated frequency	50 Hz	50 Hz	50 Hz	50 Hz	50 Hz	50 Hz	50 Hz	50 Hz	50 Hz
Rated current	4 A	7,6 A 6,1 A	8,3 A	6,2/4,75 A	11 A	10,6/7,3 A	12,3 A	9,7/6,8 A	11,8/8 A
Insulation class	I	I	I	I	I	I	I	I	I
Type of appliance	B	B	B	B	B	B	B	B	B
Use	S1	S1	S1	S1	S1	S1	S1	S1	S1
Protection against ingress of liquids	ordinary	ordinary	ordinary	ordinary	ordinary	ordinary	ordinary	ordinary	ordinary
Degree of protection against electric shock Type	B 	B 	B 	B 	B 	B 	B 	B 	B 
Output power	0,42 kW	0,9 kW 0,8 kW	0,95 kW	0,95 kW	1,5 kW	1,7 kW	1,7 kW	1,7 kW	2,4 kW
Maximum flow	650 l/min	1000 l/min 650 l/min	1400 l/min	1400 l/min	1500 l/min	1500 l/min	1900 l/min	1900 l/min	2150 l/min
Max. head for continuous service	1300 mm H <sub>2</sub> O	2600 mm H <sub>2</sub> O	1700 mm H <sub>2</sub> O	1700 mm H <sub>2</sub> O	2600 mm H <sub>2</sub> O	2600 mm H <sub>2</sub> O	2000 mm H <sub>2</sub> O	2000 mm H <sub>2</sub> O	2350 mm H <sub>2</sub> O
Sound pressure w/o box**	61 dB (A)	64,8 dB (A) 65 dB (A)	69,4 dB (A)	69,4 dB (A)	69,6 dB (A)	69,6 dB (A)	69,8 dB (A)	69,8 dB (A)	72,6 dB (A)
Sound pressure with box**	58 dB (A)	62,8 dB (A) 61 dB (A)	62,7 dB (A)	62,7 dB (A)	62,4 dB (A)	62,4 dB (A)	65,5 dB (A)	65,5 dB (A)	65,5 dB (A)
Sound pressure with sound-proof box**	52 dB (A)	- 56 dB (A)	61,6 dB (A)	61,6 dB (A)	61,3 dB (A)	61,3 dB (A)	62 dB (A)	62 dB (A)	61,6 dB (A)

	Alternating current	IEC 417-5032
	Earthing	IEC 417-5019
	Open (disconnected from the main electric supply)	IEC 417-5008
	Closed (connected to the main electric supply)	IEC 417-5007

## General 60 Hz running data Dental aspirator

Model	TURBO-JET 1 modular	Turbo HP due	Turbo HP tre	Turbo HP tre	Turbo HP tre 2V	Turbo HP quattro	Turbo HP quattro 2V
		TURBO-JET 2 modular					
Rated voltage	230 V ~	230 V ~	230 V ~	220/380 V 3 ~	220/380 V 3 ~	220/380 V 3 ~	265/460 V 3 ~
Rated frequency	60 Hz	60 Hz	60 Hz	60 Hz	60 Hz	60 Hz	60 Hz
Rated current	4,6 A	7,1 A	11,7 A	7,4/4,3 A	9,9/5,7 A	10,4/6 A	11,2/6,5 A
Insulation class	I	I	I	I	I	I	I
Type of appliance	B	B	B	B	B	B	B
Use	S1	S1	S1	S1	S1	S1	S1
Protection against ingress of liquids	ordinary	ordinary	ordinary	ordinary	ordinary	ordinary	ordinary
Degree of protection against electric shock Type	B 	B 	B 	B 	B 	B 	B 
Output power	0,52 kW	0,92 kW	1,35 kW	1,35 kW	1,75 kW	2 kW	2,85 kW
Maximum flow	750 l/min	900 l/min	1600 l/min	1600 l/min	1600 l/min	2350 l/min	2600 l/min
Max. head for continuous service	1500 mm H <sub>2</sub> O	2600 mm H <sub>2</sub> O	2000 mm H <sub>2</sub> O	2000 mm H <sub>2</sub> O	2800 mm H <sub>2</sub> O	2100 mm H <sub>2</sub> O	2600 mm H <sub>2</sub> O
Sound pressure w/o box**	66,7 dB (A)	70 dB (A)	69 dB (A)	69,2 dB (A)	72,4 dB (A)	68,5 dB (A)	74,1 dB (A)
Sound pressure with box**	60,7 dB (A)	64,6 dB (A)	66,2 dB (A)	65,6 dB (A)	71,6 dB (A)	70 dB (A)	72,5 dB (A)
Sound pressure with sound-proof box**	57,3 dB (A)	62,6 dB (A)	62 dB (A)	59 dB (A)	69,6 dB (A)	69 dB (A)	70,8 dB (A)

**This appliance cannot work in the presence of an anaesthetic mixture flammable with air, oxygen or nitrous oxide.**

**\*\* Sound pressure level tested according to the standard ISO 3746-1979 (E).  
Parameters: r or d=1 - Background noise: 34 dB (A) - Instrument: Brüel & Kjær Type 2232.**

**Manufactured by CATTANI S.P.A. - PARMA - ITALY**

ENGLISH

## Introduction

This booklet is intended to illustrate the installation and starting of the appliance. It also informs of possible dangers and about the precautions to be taken for accident prevention.

This manual should be always available for consultation during unpacking, use, installation and starting of Turbo HP or Turbo-Jet modular.

Our **updated** manuals are available on the web site [www.cattani.it](http://www.cattani.it). We recommend their consultation especially for updates about **safety**.

## Signals and warnings

- **Electrical shock risk: also 230 V ~ can be lethal.**



- **Biological danger, risk of infections from epidemic diseases.**



- **General danger sign.**



- **Personal protections for heavy works.**



- **Personal protections against biological danger.**



- **High temperature.**



- **Keep the room free from flammable, corrosive or explosive material.**



- **Compulsory direction of flow or of rotation.**



**Warning signs cannot always fully express danger warnings, therefore it is necessary that the user reads the warnings and keeps them in due consideration.**

**Failure to observe a danger sign or warning may harm operators or patients.**

**Safety devices must not be removed. Appliances or their functioning must never be modified.**

Despite all our efforts, it is still possible that danger warnings are not exhaustive: we apologise to the users and kindly request them to care for all danger sources that might have passed unnoticed and to inform us accordingly.

## Installation and starting

### Recommended precautions

Before unpacking the appliance, check the warning shockwatch on the carton. In case of it being red or the carton being damaged, accept the material reserving the right to examine the machine.

Unpack the appliance following the instructions shown on the package. The carton is recyclable. Dispose of it in compliance with regulations in force.

The machine installation must be carried out by a specialist equipped with the necessary tools. Install the appliance in a clean location, far from heat sources, humidity and dust. The aspirator can be installed outdoors (on a balcony, in veranda or gardens), provided that it is sheltered from rain, splashing, humidity, frost and direct sunshine.

In the plant room temperature can range from a minimum of + 5 °C to + 35 °C max.

Machines fitted with box, for indoors our outdoors installation, can be supplied with antifreeze device.

In case the plant room must be ventilated or air-conditioned, we suggest to contact a thermo-technician for a personalized project. The plant room must be closed to patients and extra-neous people. If such a room is not available, machines must be protected by a suitable cover, which must not be easy to remove. Use protections and danger warning boards to prevent accidental risk from electrical shocks or the possibility (unlikely but not excludible) of fire, explosion and contaminating air or liquid leakage. Use indoors and outdoors boxes designed and produced by the manufacturer of the machines only.

Keep the plant room free from flammable material. Make sure that there is no possibility for gas leakages.

Do not connect damaged appliances to the mains. Do not use extension leads, multiple plugs or sockets. Before connecting the machine to the mains, ascertain that the feeding line is complying with the regulations C.E.I. 64-8 and that a thermal switch and a residual current operated circuit-breaker (class A or B) **(16A)** according to the regulations EN 61008-1 are present.

Light coloured, wooden, linoleum, rubber or marble floors can change colour or get marked if they are kept in contact with rubber vibration-proof devices **(1)**. Therefore, it is necessary to use a rubber sheet or some other suitable material to isolate vibration-proof devices from the floor.

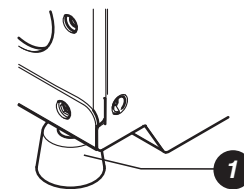
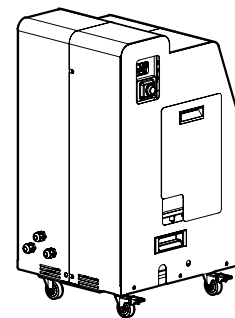
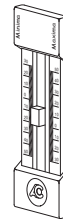
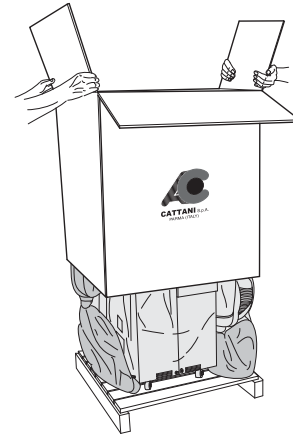

## Installation

Before connecting the aspirator to the piping of the centralized system, ascertain that aspiration piping is clean as heavy debris could damage the appliances.

Connect the PVC light grey aspiration tube (2b) (supplied with the machine) to the 50 mm Ø tube-holder (2) ("aspirated fluid inlet"). The other end of the same tube must be connected to the aspiration piping (3) coming from the surgeries (page 18).

The black heat resistant exhaust air pipe (4b), fitted with a metal spiral, must be connected to the 50 mm Ø tube-holder (4) ("exhaust air outlet"). Connect the other end of the pipe to the antibacterial filter (5), passing preferably through a silencer (5a) supplied with the aspirator. The hot air coming from the antibacterial filter must be conveyed outside.

Connect the 18 mm Ø tube-holder (6) to the liquid drain pipe. In the version fitted with Hydrocyclone the aspirator is draining liquids by gravity, therefore these can never be drained towards the top.

The 10 mm Ø tube-holder (8) ("emergency drain") must be connected to the liquid drain pipe.

The piping connecting the machine to the aspiration and draining system should be flexible to dampen the small vibrations produced by the aspirator.

The aspiration piping should be run in the floor and at a point near the aspirator it should rise about 30 cm to reach the tube-holder (2) (Draw. A and B, page 61).

If Turbo HP or Turbo-Jet modular is installed on a lower floor than the dental units, the aspiration piping must not enter the centrifugal separator perpendicularly. Rather, place a few metres of piping horizontally on the same level of the machine and then install it at the centrifugal separator inlet which is on a higher level (use a flexible pipe) (Draw. B, page 61). The aspirated fluid is reaspirated by the machine.

After the installation, connect the power cable to the mains according to the regulation EN 61008-1. Finally connect the low voltage users line: the clamps 1-2-3 of the circuits AC 48B/AC58B and AC58 (Draw. F-G-H, pages 67-68-69) to the users line (12) (page 19 and Draw. C, page 62) which is feeding all the dental units of the same system with connections in parallel. Ascertain that the contact on the dental unit is clean (free contact without voltage).

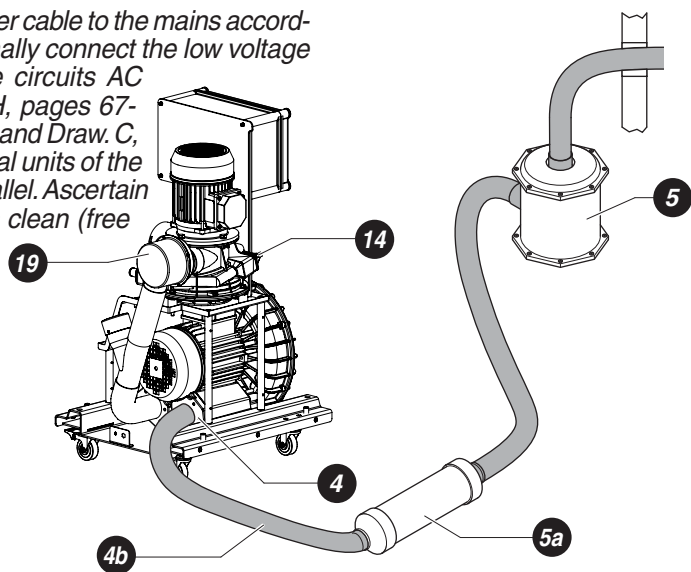
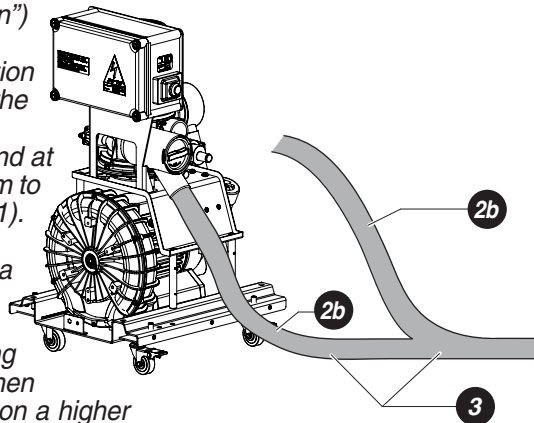
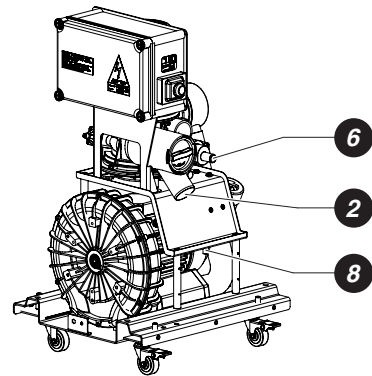

### Installation in parallel

It is advisable to install in parallel only machines with the same flow and head values.

With the installation of 2 or 3 aspirators in parallel (Draw. 1) the total flow is doubled or tripled, provided that the diameter of the main piping is increased of 10 mm for each additional aspirator unit. In the same way the diameter of the exhaust air pipe must be increased.

The Turbo HP models are always supplied complete with silencer with one-way valve (det. 19, page 18), whereas for the Turbo-Jet 2 models the silencer with one-way valve is supplied apart.

For the groups of Turbo-Jet modular and Turbo HP installed in parallel it is necessary to install a starter in the plant room and a two-ways PB unit on each dental unit.

After connecting the aspirators in parallel to the same main piping, connect in parallel the users wires (AC 48B scheme, Draw. F, page 67) coming from the different dental units.

With multiple aspirators in parallel it can occur that one unit stops and that the operators do not notice it. In order to bring this to the clinic staff's attention, 2 connections in each control panel (clean contact) allow a remote alarm signal to be connected in a room under frequent control.

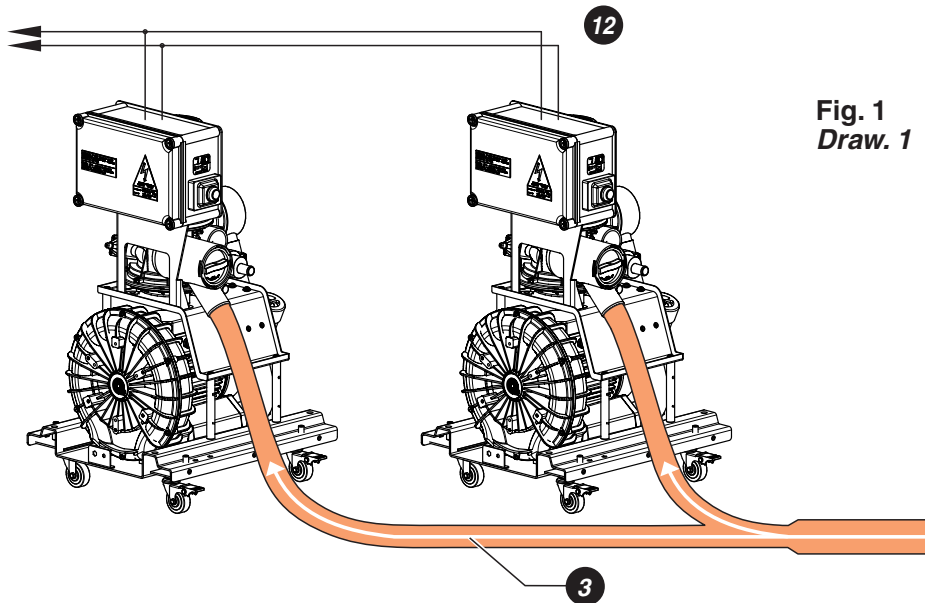

Fig. 1  
Draw. 1

## Starting, final test and users instruction

Install and connect the aspirator, select the position ON on the switch, which will light up after one of the dental units has started working. At this point aspiration will start.

To check if the aspirator is working correctly, it is advisable to carry out the dynamic tests (see the "General running data" at pages 14-15 and the working diagrams at pages 63-64).

Users must be instructed on the use and routine maintenance of new, not used, and therefore not yet contaminated, machines.

Show users how to carry out maintenance correctly using Puli-Jet plus (A) - (by means of Pulse-Cleaner) (B) - and Anti-foaming Tablets (C).

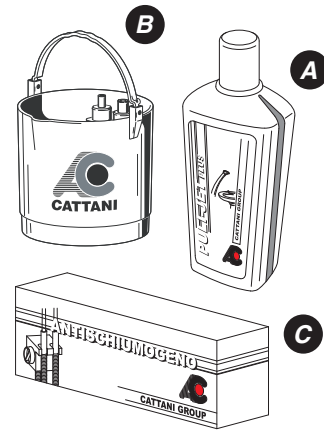

## Working

The aspirating unit (9) (through pipe 10) creates vacuum inside the centrifugal separator (11). The fluid coming from the dental units enters the centrifugal separator (11) from the collecting pipe (2). The centrifugal separator separates air from liquids: air is exhausted outside through the pipe (4) (page 18) whereas liquids (in the version without amalgam separator) are drained to the sewage through the waste pipe connected to the tube-holder (6) (page 18).

The centrifugal separator (11) is starting before the aspirating unit (9), this allows to drain the liquids which might collect inside the centrifugal separator before aspiration starts. Moreover, when the machine is switched off a timer (adjustable) is keeping the motor running for min. 10" - max. 120".

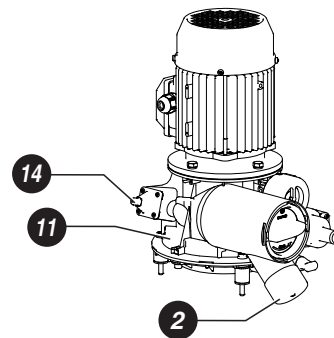

## Amalgam Separator ISO 18

On request, Turbo-Jet 1-2 modular units can be supplied with the amalgam separator "Hydrocyclone ISO 5,5" and Turbo HP units with the "Hydrocyclone ISO 18" having their separate manuals.

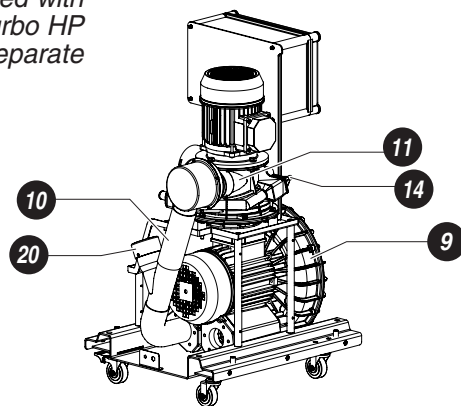



## Routine maintenance

Routine maintenance must be entrusted to specially instructed surgery staff.

- We recommend to pay special attention to all danger signals and to use goggles, gloves and disposable overalls for personal protection.



### Every evening

- at the end of every working day aspirate a solution of Puli-Jet plus disinfectant using Pulse Cleaner;
- disconnect the machine from the mains before any intervention.

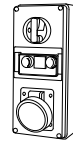

### Daily

- place the Antifoam Tablets on the dental unit filters.

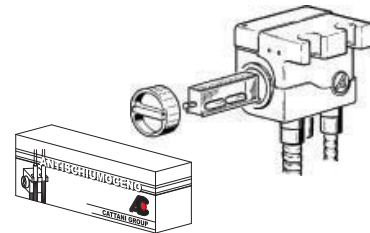

### Periodically

- keep the aspirator filter clean.

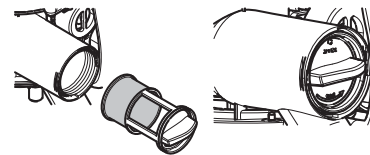

### Occasionally

- make sure that the aspirator ventilation is not obstructed;
- keep the plant room free from anything not related to the machines, especially from flammable material. Make sure that there is no possibility for the formation of corrosive, flammable and explosive mixtures.

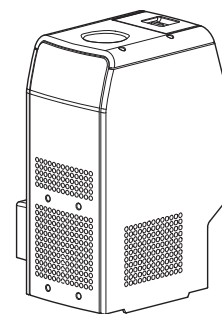

BOX FOR TURBO HP due

## Extraordinary maintenance

Extraordinary maintenance must be entrusted to a trained technician in possession of original spare parts:

- pay special attention to danger signals. Use goggles, gloves and disposable overalls for personal protection;
- check that routine maintenance has been duly carried out and make sure that Magnolia products are used;
- before any intervention carry out a series of washes with Puli-Jet plus disinfectant, then wait 60 minutes for a complete disinfectant action. For more safety, it is advisable to disinfect the evening before the intervention;
- every 6/9 months check the condensers efficiency.



- Recommended every 12 months:

- check the aspirator noise level according to the regulation 3047 (E) (see the "General running data" at pages 14-15);
- remove dust from the circuit AC 80 inside electronic components using a blast of dry air not exceeding 2 bar pressure. By means of a 6 bar blast of air clean also the small holes on the frontal cover of the aspirating unit (15);
- check the conditions of plastic hoses, in particular the hoses under pressure connecting the centrifugal separator (11) and the Hydrocyclone ISO. We suggest to replace these hoses every 12-18 months.



- Recommended every 18-24 months:

- check the working conditions of the centrifugal separator (11) and re-circulation valve (14).

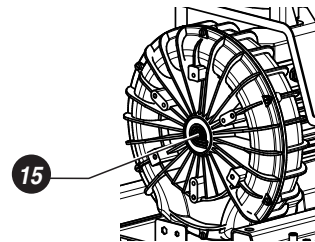

- Recommended every 10.000 working hours:

- every time a component containing a rubber part ("O" ring, gasket or seal) is disassembled, replace the rubber part;
- replace the motors bearings;
- where routine maintenance is not carried out properly or unsuitable products are used, train the staff and inform the person in charge.

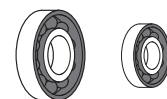
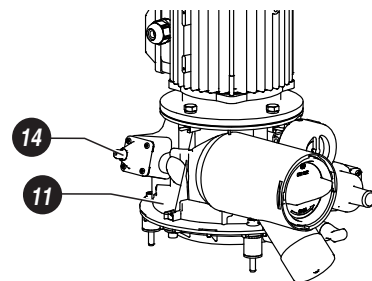

## **Important notices**

- Appliances are guaranteed for one year from the date of sale, provided that the warranty slip is returned to the manufacturer with date of sale, retailer's and customer's name.
- Warranty and manufacturer's liability cease in case appliances are treated with products which are unsuitable or different from those recommended by the manufacturer and also in case appliances are improperly used or tampered with operations of any kind carried out by people who are not authorized by the manufacturer.
- The manufacturer, concessionaires, agents and authorized technicians are at customers' disposal for advice and assistance and to supply literature, spare parts and anything useful.
- The manufacturer reserves the right to modify the products for improvements, for technical, normative and functional reasons or for problems due to the availability of products or semi-finished products, without prior notice.
- Our **updated** manuals are available on the web site [www.cattani.it](http://www.cattani.it). We recommend they are consulted especially for updates about **safety**.

## **Transport and storage**

- Packed appliances can be transported and stored at a temperature ranging from - 10 °C to + 60 °C.
- Packages must be kept away from water and splashing and cannot tolerate humidity >70%.
- Packages with the same weight can be stored in piles of three only.

## **Transport of second-hand appliances**

- Before packing, cleanse and disinfect with Puli-Jet plus (refer to the paragraphs "Routine maintenance" and "Extraordinary maintenance").
- Close with polyethylene plugs all machine inlets and outlets.
- Place the machine into a polyethylene bag, seal and pack it in 3-layer corrugated board.

